

MILÀ

Milà es fruto del diseño industrial, una creación más allá de modas efímeras. La practicidad unida a la belleza de unas formas sencillamente elaboradas.

Creada en la utilidad para satisfacer las más altas exigencias. Milà es atemporal, pero a la vez está fuertemente ligada con el mundo en el que vivimos. Preocupada por el medio ambiente, la colección Milà ofrece soluciones ecológicas sin sacrificar ni un ápice en la presencia.

Milà comes straight from the industrial design world; it is a creation that goes far beyond ephemeral fads, a practical object combined with beautiful forms. Created from a utilitarian need but aiming to satisfy the highest expectations. Milà is timeless but of our times. With concern for the environment Milà offers ecological solutions without sacrificing an iota of function.

Milà est le pur fruit du design industriel, une création qui va plus loin que les effets de mode éphémères. La praticité en parfaite union avec la beauté de formes simplement élaborées. Créée pour parfaite un besoin d'utilité afin de satisfaire toutes les exigences. Milà est à la fois intemporelle et étroitement liée au monde dans lequel nous vivons. Résultat d'une réelle préoccupation environnementale, la collection Milà offre des solutions écologiques sans sacrifier un iota de prestance.





004.105.110



La colección está concebida para un uso racional, sobretodo en hostelería. La maneta, colocada en la parte delantera, permite cerrar el grifo sin mancharlo con las manos mojadas. La forma convexa y continua del cuerpo evita que el agua se estanque, facilitando la limpieza y el mantenimiento diario del grifo. La apertura en frío favorece el ahorro energético y economiza el uso del agua. Beneficios, todos estos, que permiten un ahorro considerable en el uso comercial, pero perfectamente aplicables también a la residencia particular.





004.551.110 + 004.301.110



The Mila collection was conceived to be particularly suitable for hotels, business premises and similar public locations. By placing the handle at the front, the mixer can be opened and closed without allowing drips from wet hands going onto the main body. The continuous and convex shape of the body discourages water to settle on the surface reducing surface cleaning. The mixer opens in the cold water position, saving energy and resources. These benefits not only permit considerable savings in commercial use but are also applicable in the home.

La collection est conçue pour une utilisation rationnelle, tout spécialement pour l'hôtellerie. La manette, située sur l'avant, permet de fermer le robinet sans le salir avec les mains mouillées. La forme convexe et continue du corps évite que l'eau y stagne, facilitant ainsi le nettoyage et l'entretien quotidien du robinet. L'ouverture en eau froide facilite l'économie énergétique et économise la quantité d'eau nécessaire. Tous ces bénéfices qui permettent une économie importante lors d'un usage professionnel sont d'autant plus valides pour la résidence particulière.

DIMENSIONES DIMENSIONS

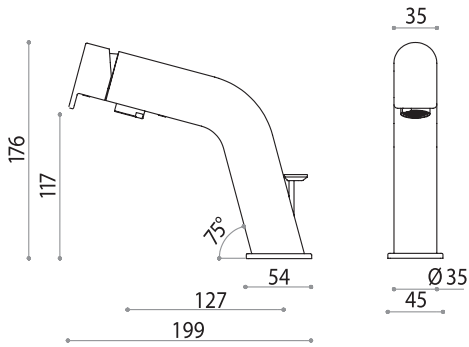

004.186.____

Monomando lavabo con válvula automática
Single lever basin mixer with pop-up
Mitigeur lavabo avec vidage automatique

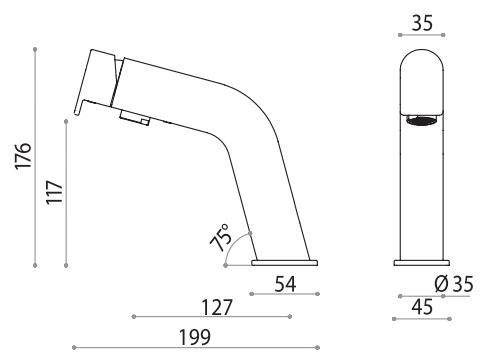

004.106.____

Monomando lavabo sin válvula
Single lever basin mixer without pop-up
Mitigeur lavabo sans vidage

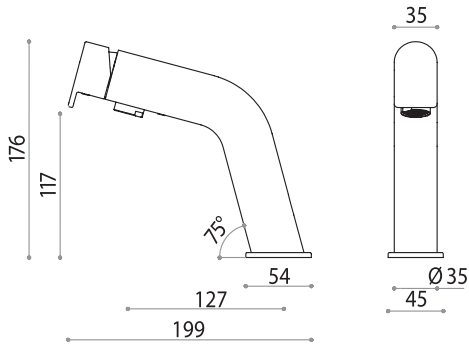

004.196.____

Monomando lavabo con válvula push
Single lever basin mixer with push drain
Mitigeur lavabo avec vidage push

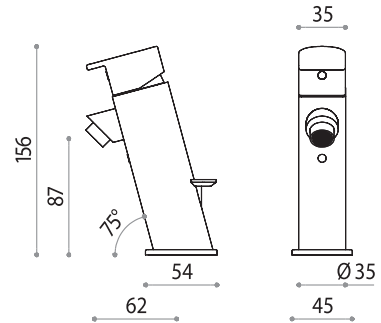

004.187.____

Monomando lavabo con válvula automática
Single lever small basin mixer with pop-up
Monomando lavabo con válvula automática

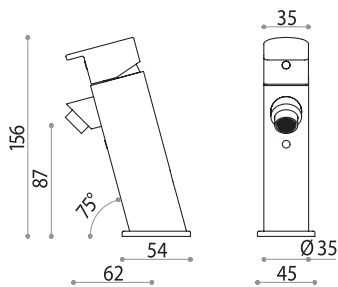

004.107.____

Monomando lavabo sin válvula
Single lever small basin mixer without pop-up
Mitigeur lavabo pour lave-mains sans vidage

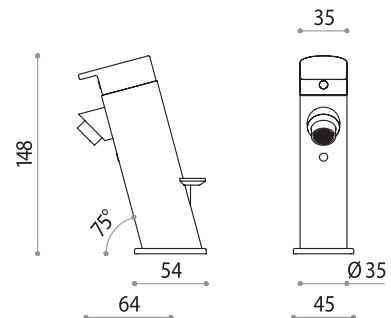

004.183.____

Grifo de agua fría con válvula automática
Cold water mixer with pop-up
Robinet lavabo eau froide avec vidage automatique

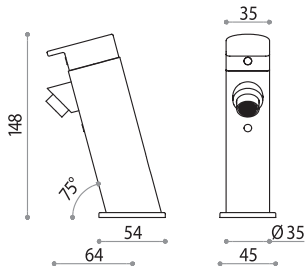

004.103.____

Grifo de agua fria sin válvula
Cold water mixer without pop-up
Robinet lavabo eau froide sans vidage

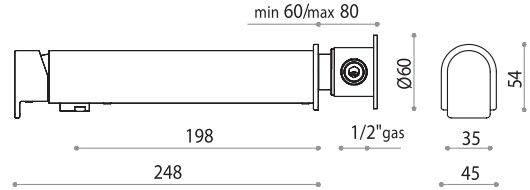

004.105.____

Monomando lavabo mural
Single lever wall mounted basin mixer
Mitigeur lavabo mural

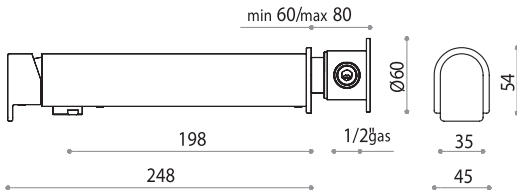

004.195.____

Monomando lavabo mural con válvula push
Single lever wall mounted basin mixer with push drain
Mitigeur lavabo mural avec vidage push

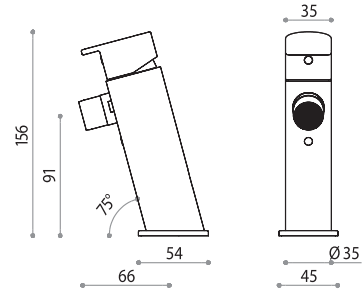

004.386.____

Monomando bidé con válvula automática
Single lever bidet mixer with pop-up
Mitigeur bidet avec vidage automatique

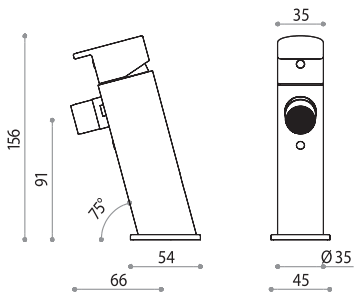

004.306.____

Monomando bidé sin válvula
Single lever bidet mixer without pop-up
Mitigeur bidet sans vidage

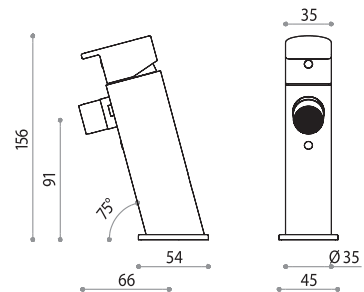

004.396.____

Monomando bidé con válvula push
Single lever bidet mixer with push drain
Mitigeur bidet avec vidage push

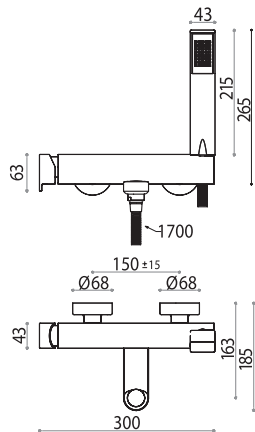

004.401.____

Monomando baño-ducha con complementos
Single lever bath-shower with handshower
Mitigeur bain-douche mural avec douchette

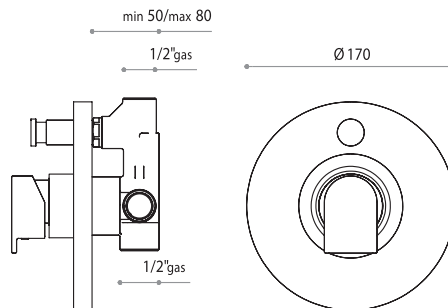

004.432.____

Monomando baño-ducha empotrado 1/2"
1/2" concealed single lever mixer for bath and shower
Mitigeur bain-douche encastré 1/2"

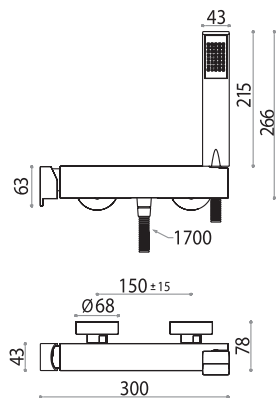

004.406.____

Monomando ducha mural con complementos
Single lever wall mounted shower with handshower
Mitigeur douche murale avec douchette

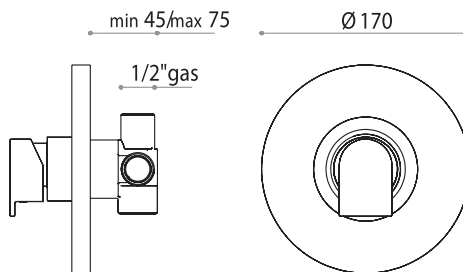

004.431.____

Monomando ducha empotrada 1/2"
1/2" concealed single lever mixer for shower
Mitigeur douche encastrée 1/2"

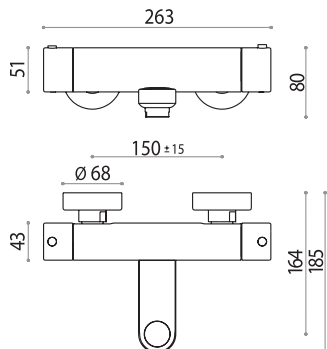

004.551.____

Termostática baño-ducha mural sin complementos
Thermostatic wall-mounted bath and shower mixer without handshower
Thermostatique bain-douche mural sans douchette

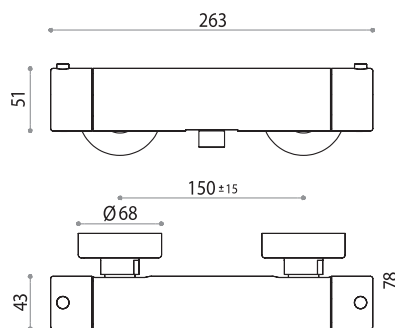

004.556.____

Termostática ducha mural sin complementos
Thermostatic wall-mounted shower mixer without handshower
Thermostatique douche murale sans douchette

MILÀ

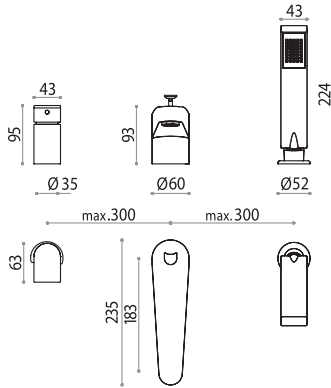

004.403.____

Monomando baño-ducha sobremesa 1/2"
1/2" single lever deck-mounted bath and shower
Mitigeur bain-douche sur gorge 1/2"

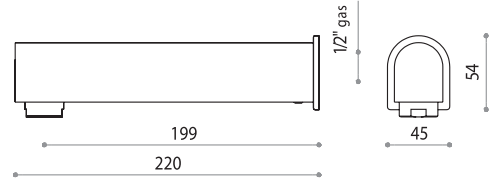

004.611.____

Caño de pared sin inversor
Wall-mounted tub spout without diverter
Bec mural sans inverseur

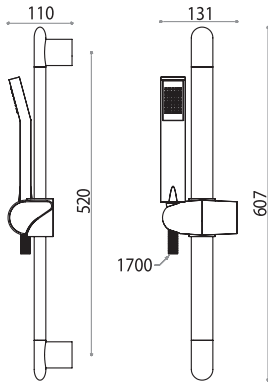

004.331.110

Kit completo de ducha
Shower kit complete
Kit de douche complet

TANGENT

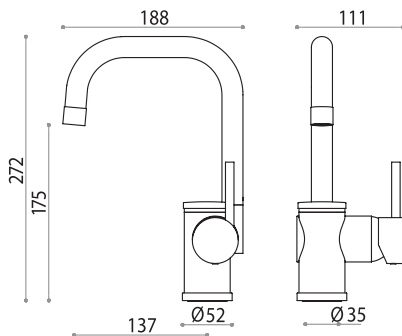

041.186.110

Monomando lavabo con válvula automática
Single lever basin mixer with pop-up
Mitigeur lavabo avec vidage automatique

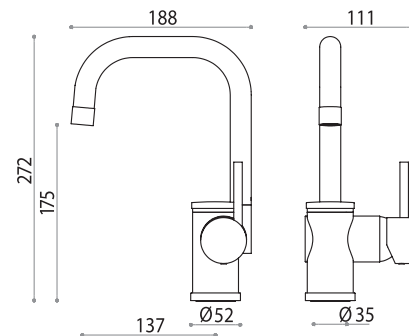

041.106.110

Monomando lavabo sin válvula
Single lever basin mixer without pop-up
Mitigeur lavabo sans vidage